

## 2 Micron High Power Mode-Locked Fiber Laser AP-ML1

This world's first 2 $\mu$ m mode-locked fiber laser offers picosecond pulse width and high beam intensity, providing a new state-of-the-art tool to research and industry applications.

AdValue Photonics' 2 $\mu$ m fiber lasers provide many advantages over traditional bulk Ho and Tm solid state lasers with their compact size, high efficiency, low maintenance, and ease of operation.

### Applications:

- Mid-IR generation
- Nonlinear optics studies
- Spectroscopy
- Research & development

### Features:

- Short pulse width
- Broad spectral bandwidth
- High peak power
- Near diffraction limited beam quality
- Turn-key system with no maintenance



### Optical Characteristics:

Parameter	Specification	
	1.95 $\mu$ m Option	2.07 $\mu$ m Option
Operating wavelength	1.95 $\pm$ 0.05 $\mu$ m	2.07 $\pm$ 0.02 $\mu$ m
Average power (nominal)	1 W	300 mW
Pulse width	<3 picoseconds	<2 picoseconds
Pulse repetition rate	20-40 MHz (non-adjustable factory set)	20-40 MHz (non-adjustable factory set)
Max. peak power	>10 kW	>5 kW
Beam quality, M <sup>2</sup>	< 1.3	
Output polarization	Random (option: linearly polarized)	
Output beam	Collimated beam, diameter $\sim$ 5 mm	
Output fiber	Single mode fiber, 6 mm armored cable, 0.5 m cable length (Polarization maintaining fiber for linearly polarized option)	
Fiber termination	Collimator, housing dimensions $\Phi$ 35 x 97 mm	

(Customization options available.)

Specifications subject to change without notice

## General Characteristics:

Parameter	Specification
Operating temperature	+10 to +30 °C
Storage temperature	-10 to +70 °C
Cooling	Forced air
Power requirement	AC 100~240 V (50/60Hz)
Power consumption	< 40 W
Warm-up time	20 minutes
Package dimensions	448.6(W) x 433(D) x 132.5(H) mm

## Mechanical Outline:

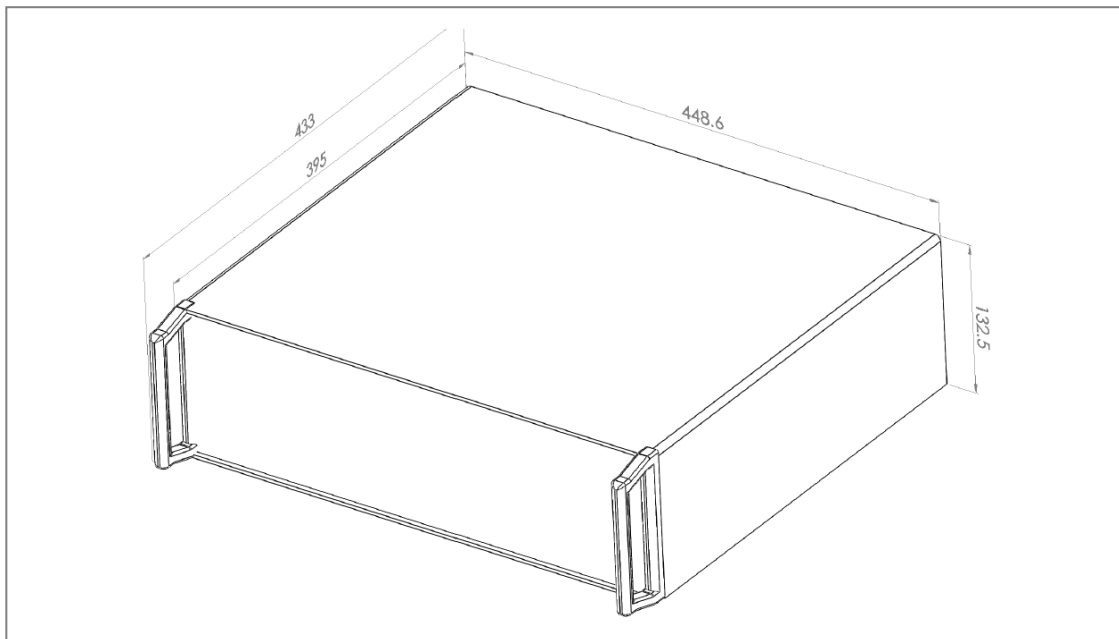

## Ordering Information:

Part Number:	AP-ML1	-	xxxx	-	xx or mxxx	-	RP or LP		
			Operating Wavelength: 1950 = 1.95±0.05 μm 2070 = 2.07±0.02 μm		Output Power: 01 = 1 W m300 = 300 mW		Polarization: RP = random polarization LP = linear polarization		

(For special request, please contact AdValue Photonics at 1-520-790-5468 or [sales@advaluephotonics.com](mailto:sales@advaluephotonics.com).)



Specifications subject to change without notice

## 2 Micron Mode-Locked Fiber Laser AP-ML

This world's first 2 $\mu$ m mode-locked fiber laser offers sub-picosecond pulse width and high beam intensity, providing a new state-of-the-art tool to research and industry applications.

AdValue Photonics' 2 $\mu$ m fiber lasers provide many advantages over traditional bulk Ho and Tm solid state lasers with their compact size, high efficiency, low maintenance, and ease of operation.

### Applications:

- Mid-IR generation
- Nonlinear optics studies
- Spectroscopy
- Research & development



### Features:

- Short pulse-width
- Broad spectral bandwidth
- Diffraction limited beam quality
- Turn-key system with no maintenance

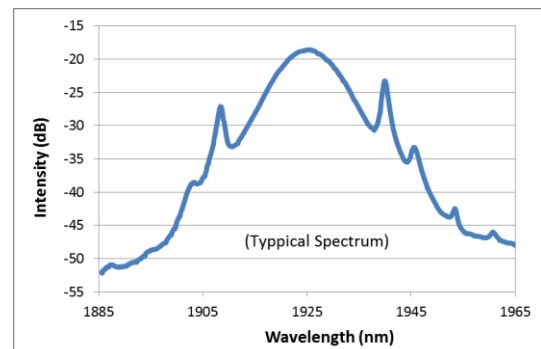

### Optical Characteristics:

Parameter	Specification	
	950 fs Option	350 fs Option
Operating wavelength	1.95 $\pm$ 0.05 $\mu$ m	1.95 $\pm$ 0.05 $\mu$ m
Average power (nominal)	5 mW	3 mW
Pulse width	< 950 femtoseconds	< 350 femtoseconds
Pulse repetition rate	20-40 MHz (non-adjustable factory set)	30-50 MHz (non-adjustable factory set)
Spectral bandwidth	> 6 nm	> 18 nm
Beam quality, M <sup>2</sup>	< 1.1	
Output polarization	Random	
Output fiber	SMF-28 single mode fiber, 3 mm jacket, 1 m length, no connector	

(Customization options available.)

*Specifications subject to change without notice*

## General Characteristics:

Parameter	Specification
Operating temperature	+20 to +30 °C
Storage temperature	-10 to +70 °C
Cooling	Forced air
Power requirement	AC 100~240 V (50/60Hz)
Power consumption	< 15 W
Warm-up time	20 minutes
Package dimensions	260(W) x 340(D) x 105(H) mm

## Mechanical Outline:

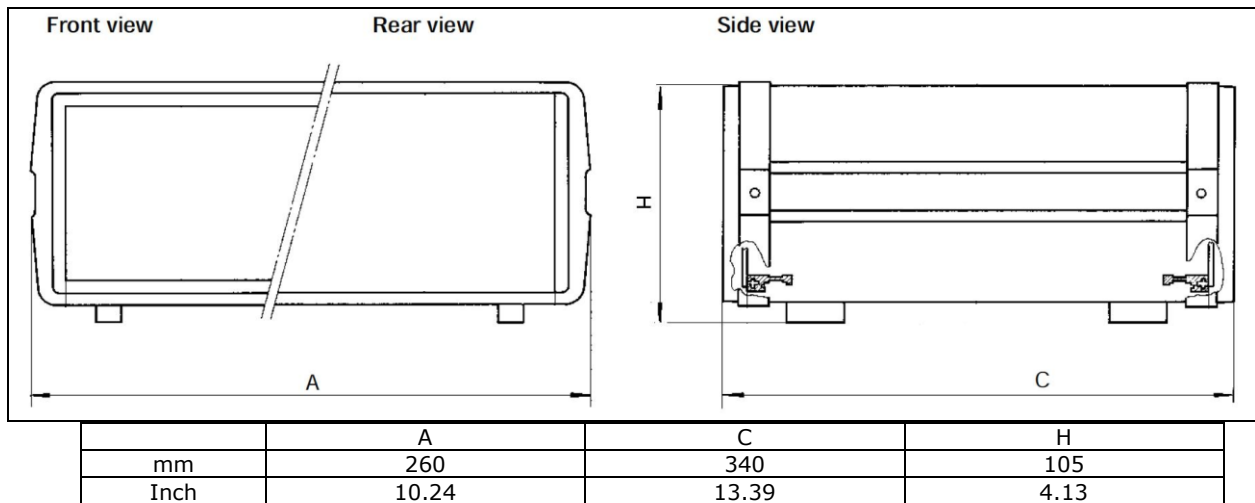

## Ordering Information:

Part Number:	AP-ML	-	1950	-	mxxx	-	RP	xxx
			Operating Wavelength: 1950 = 1.95±0.05 μm		Output Power: m003 = 5 mW m005 = 3 mW		Polarization: RP = random polarization	Pulse Option: 950 = 950 fs Option 350 = 350 fs Option

(For special request, please contact AdValue Photonics at 1-520-790-5468 or [sales@advaluephotonics.com](mailto:sales@advaluephotonics.com).)



Specifications subject to change without notice