

# ADAPTER G3P0/M FD-1.85/M 65GHZ

SM8952

## SPECIFICATIONS

### ELECTRICAL

FREQUENCY: 0-65 GHZ  
 IMPEDANCE: 50 OHMS  
 VSWR: 1.33:1 MAX @ 65 GHZ

### MECHANICAL

500 CYCLES MIN  
 DURABILITY: 500 CYCLES MIN.  
 4.0 INCH-OUNCES MIN CONTACT TORQUE  
 8-10 LBS COUPLING NUT MATING TORQUE

TEMPERATURE RANGE: -65 TO +100 DEG C

### MATERIALS

BODY: PASS. STAINLESS STEEL  
 CONTACTS: BeCu  
 CONTACT PLATING: Au PER MIL-G-45204

ROHS COMPLIANT

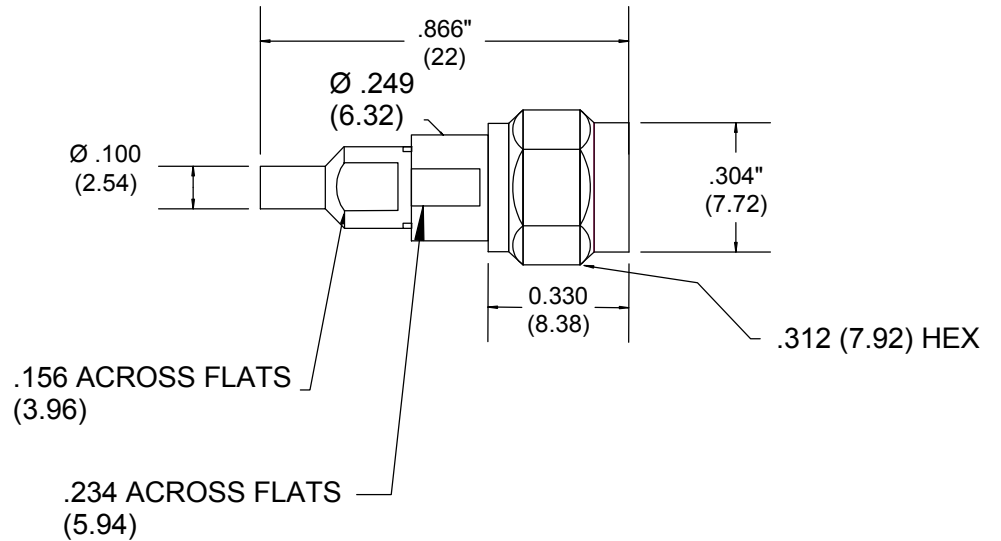

**FAIRVIEW MICROWAVE INC.**

ALLEN, TX 75013 WWW.FAIRVIEWMICROWAVE.COM

TITLE

**ADAPTER G3P0/M FD-1.85/M 65GHZ**

SIZE	CAGE CODE	DWG NO	REV
<b>A</b>	<b>3FKR5</b>	<b>SM8952</b>	<b>A</b>

ALL DIMENSIONS IN inches(MM) Typical

SCALE

SHEET