

MODEL HX4210

100MHz 10x Frequency Divider
 ULTRA LOW PHASE NOISE

- 100MHz Input, 10MHz Output
- +10dBm Input / Output
- -170 dBc/Hz Additive Phase Noise
- DC Supply: 8V_{DC} to 12V_{DC} (100mA)
- Integrated Low Noise Bias Network



SUMMARY

The Holzworth HX4210 100MHz 10x Frequency Divider is a high grade laboratory accessory. An emphasis was placed on maintaining the low jitter and phase noise of an external reference or frequency source to maintain the integrity of system timing and noise.

The HX4210 Frequency Divider is a laboratory grade reference divider that has a high output power and will operate with a broad range of power supplies. Holzworth products are 100% final performance tested for phase noise verification¹.

SPECIFICATIONS² PRELIMINARY

PARAMETER	MIN	TYP	MAX	UNITS	COMMENTS
Input Frequency	90	100	110	MHz	50 ohms
Output Frequency	9	10	11	MHz	50 ohms
Input Power	5	10	15	dBm	50 ohms
Output Power	9	11	13	dBm	50 ohms
Phase Noise (Additive)		-170		dBc/Hz	Output Referred (100MHz Input)
Output Harmonics					
2 nd Harmonic		-40	-30	dBc	10MHz ±2MHz
3 rd Harmonic		-60	-30	dBc	10MHz ±2MHz
Spurious Output		-70		dBc	
DC Supply	8		12	V _{DC}	±10%, 50mA
RF Connectors	SMA Female				
DC Connector	SMB Male				
Housing Dimensions (LxWxH)	1.75" x 1.5" x 0.5" (44.5mm x 38.1mm x 12.7mm)				

¹ Final performance verification at RF_{INPUT}= 100MHz / +10dBm, RF_{OUTPUT}= 10MHz, Residual Setup

² Specifications are subject to change per the discretion of Holzworth Instrumentation, Inc.

RoHS Compliant

HX4210 PERFORMANCE DATA

The phase noise data provided here demonstrates typical performance of the HX4210 100MHz 10x Frequency Divider under ambient laboratory conditions. Refer to Figure 1 for phase noise data and Figure 2 for a diagram of the test setup.

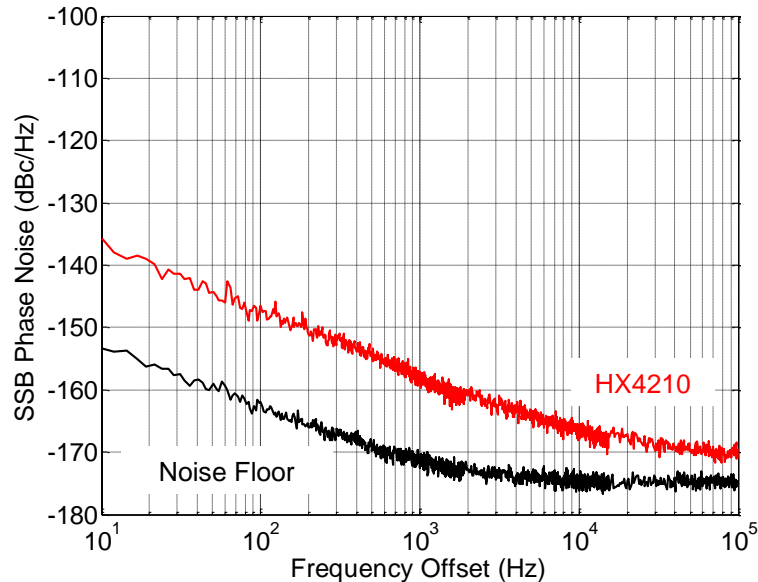

Figure 1: HX4210 Phase Noise Data

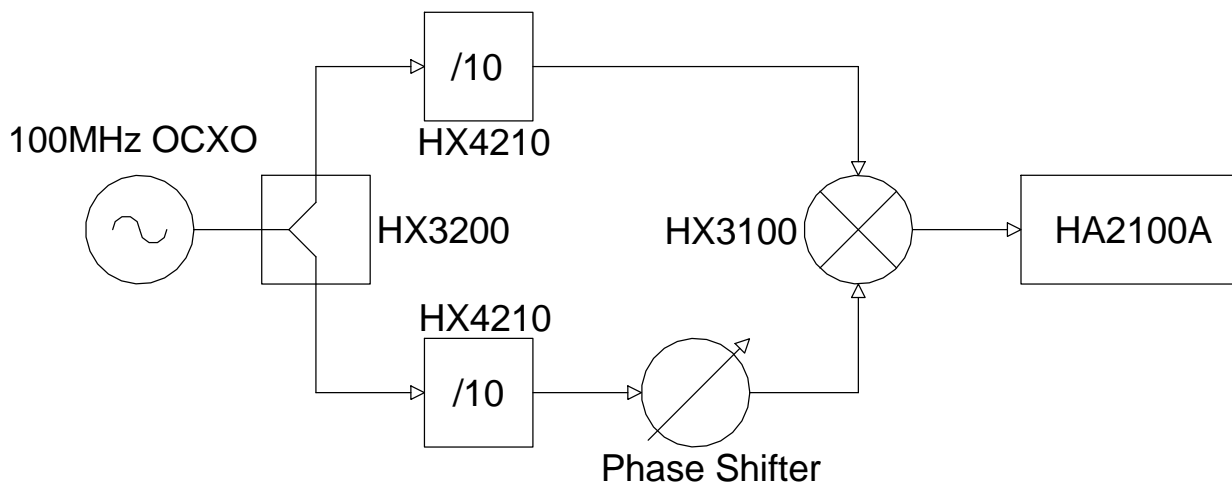
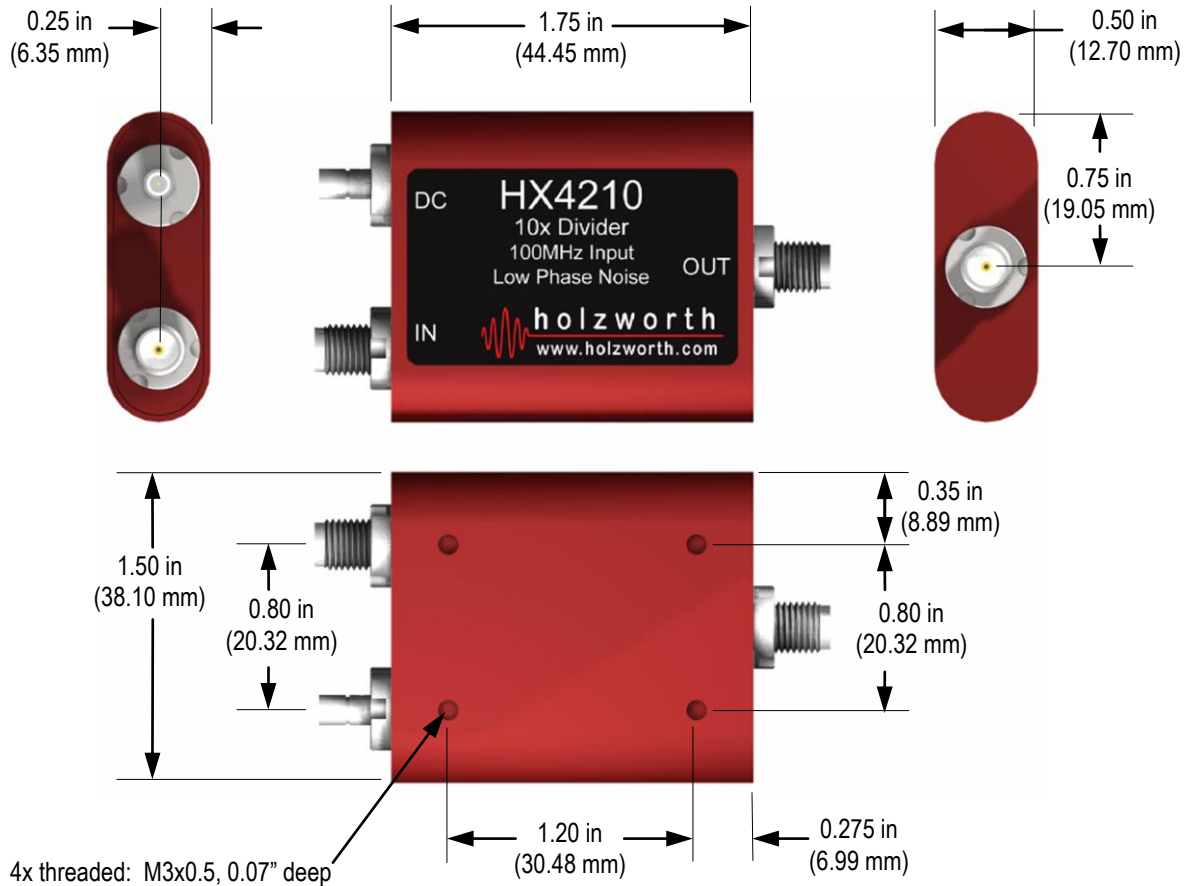

Figure 2: Phase Noise Test Setup

MECHANICAL

The HX4210 comes in a compact, shielded housing complete with threaded mounting holes for ease of system integration into various test sets.



RoHS Compliant

WARRANTY

All Holzworth frequency dividers come with a 1 year 100% product warranty covering manufacturing defects. All product repairs and maintenance must be performed by Holzworth Instrumentation. Holzworth reserves the right to invalidate the warranty for any product that has been tampered with or used improperly. Refer to Holzworth Terms & Conditions of Sales for more details.